

NOBA8

User Manual



www.audac.eu

ADDITIONAL INFORMATION

This manual is put together with much care, and is as complete as could be on the publication date. However, updates on the specifications, functionality or software may have occurred since publication. To obtain the latest instruction manual or obtain additional product information, please visit the product page on www.audac.eu. For information about software version updates, please visit www.audac.eu/software.

Index

Introduction	5
Precautions	5
Safety requirements	6
Caution servicing	6
EC Declaration of Conformity	6
Waste of Electrical and Electronic Equipment (WEEE)	7
Caution	7
Overview	8
Placement	8
Connection	9
Mounting	10
Technical specifications	12

Introduction

8" Compact bass cabinet

NOBA8 is characterized by an innovative & unique design. With its curved shape, made of 4 mm thick aircraft graded aluminum and its extremely powerful 8" woofer of 200 Watts, the NOBA8 is able to deliver an unheard low frequency response for its small woofer size.

The perfect acoustic experience is guaranteed when the entire audio frequency spectrum is equally distributed. The slick look of the NOBA8 allows it to be placed against a wall, on the ceiling or even underneath furniture, yet due to the unique composition of its parts, NOBA8 ensures a much better spreading of sound waves than other similar cabinets.

The connection is made using a terminal block connection located at the inner side of the supporting structure. This allows close placement to any wall or corner.

The NOBA bass cabinets are available in black (/B) or white (/W).

Precautions

READ FOLLOWING INSTRUCTIONS FOR YOUR OWN SAFETY

ALWAYS KEEP THESE INSTRUCTIONS. NEVER THROW THEM AWAY

ALWAYS HANDLE THIS UNIT WITH CARE

HEED ALL WARNINGS

FOLLOW ALL INSTRUCTIONS

NEVER EXPOSE THIS EQUIPMENT TO RAIN, MOISTURE, ANY DRIPPING OR SPLASHING LIQUID. AND NEVER PLACE AN OBJECT FILLED WITH LIQUID ON TOP OF THIS DEVICE

NO NAKED FLAME SOURCES, SUCH AS LIGHTED CANDLES, SHOULD BE PLACED ON THE APPARATUS

DO NOT PLACE THIS UNIT IN AN ENCLOSED ENVIRONMENT SUCH AS A BOOKSHELF OR CLOSET. ENSURE THERE IS ADEQUATE VENTILATION TO COOL THE UNIT. DO NOT BLOCK THE VENTILATION OPENINGS.

DO NOT STICK ANY OBJECTS THROUGH THE VENTILATION OPENINGS.

DO NOT INSTALL THIS UNIT NEAR ANY HEAT SOURCES SUCH AS RADIATORS OR OTHER APPARATUS THAT PRODUCE HEAT

DO NOT PLACE THIS UNIT IN ENVIRONMENTS WHICH CONTAIN HIGH LEVELS OF DUST, HEAT, MOISTURE OR VIBRATION

THIS UNIT IS DEVELOPED FOR INDOOR USE ONLY. DO NOT USE IT OUTDOORS

ONLY USE ATTACHMENTS & ACCESSORIES SPECIFIED BY THE MANUFACTURER

USE THE APPARATUS ONLY IN MODERATE CLIMATES



CAUTION – SERVICING

This product contains no user serviceable parts. Refer all servicing to qualified service personnel. Do not perform any servicing (unless you are qualified to)



EC DECLARATION OF CONFORMITY

This product conforms to all the essential requirements and further relevant specifications described in following directives: 2014/30/EU (EMC) and 2014/35/EU (LVD)



WASTE ELECTRICAL AND ELECTRONIC EQUIPMENT (WEEE)

The WEEE marking indicates that this product should not be disposed with regular household waste at the end of its life cycle. This regulation is created to prevent any possible harm to the environment or human health.

This product is developed and manufactured with high quality materials and components which can be recycled and/or reused. Please dispose this product at your local collection point or recycling centre for electrical and electronic waste. This will make sure that it will be recycled on an environmentally friendly manner, and will help to protect the environment in which we all live.

CAUTION

The symbols shown are internationally recognized symbols that warn about potential hazards of electrical products. The lightning flash with arrowpoint in an equilateral triangle means that the unit contains dangerous voltages. The exclamation point in an equilateral triangle indicates that it is necessary for the user to refer to the users manual.



These symbols warn that there are no user serviceable parts inside the unit. Do not open the unit. Do not attempt to service the unit yourself. Refer all servicing to qualified personnel. Opening the chassis for any reason will void the manufacturer's warranty. Do not get the unit wet. If liquid is spilled on the unit, shut it off immediately and take it to a dealer for service. Disconnect the unit during storms to prevent damage.

Overview



The aluminum enclosure features a grill on both sides, whereof one side includes the bass port. To allow optimal air-circulation through the bass port, make sure this side remains uncovered when installed.

Placement

The low frequencies produced by a bass cabinet are non-directional, and therefore the placement of the subwoofer in the listening area is not critical. However, few simple rules concerning its positioning can significantly influence the result.

Low frequency sound reproduction is coupled with boundaries, which results in a longer carriage and higher sound pressure level. The NOBA8 is designed in such way to allow easy placement and mounting to any wall or ceiling through the available mounting brackets.

When having multiple bass cabinets in your setup, side-by-side placement will result in an acoustic coupling between them which provides an increased SPL and punch. However some other applications will require a wider dispersion of bass, depending of the room size, layout and acoustics.

The ideal positioning of bass cabinets is highly depending of the typical application, and there is no such perfect way which is always right. Making some experiment-wise tests about placement and coupling of bass cabinets can lead to improved results.

Connection

Connection panel overview



Connection panel description

Terminal block input connection:

The connection of the NOBA8 is made using a 2-pin terminal block connection where to the wires coming from the amplifier shall be connected. There isn't any internal low-pass network provided, which means the applied signal should be filtered / processed using an external crossover or amplifier featuring active filtering or DSP processing.

Mind the polarity markings when wiring the loudspeaker cables.

Mounting

The NOBA8 comes standard delivered with a mounting bracket for on-wall installation. The installation of this bracket shall be done according to a simple 5-step procedure as described below:

Step 1: Remove the rubber feet

The cabinet comes delivered with 4 pcs of rubber feet assembled supporting the cabinet for floorstanding use. When installing the cabinet to the wall, two pcs of these rubber feet must be removed for assembly of the supporting bar. Note that the cabinet can be mounted in two directions. Depending of the required direction (position of the connections, amplifier and bass port) both feet on the upper side needs to be removed. Keep the removed screws for the next step.

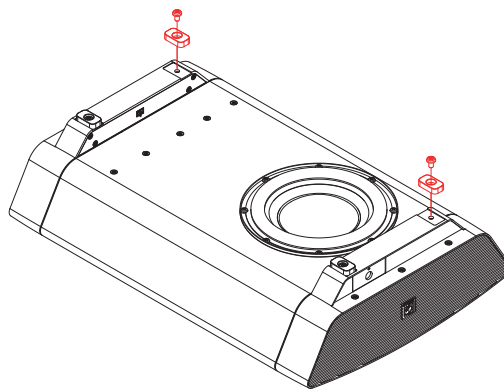

Step 2: Assembling the cabinet supporting bar

Once both rubber feet are removed, the supporting bar for hooking the cabinet to the wall plate needs to be assembled. Place the supporting bar on the position where both rubber feet were located and fix it with the screws removed in step 1. Mind the mounting direction when installing.

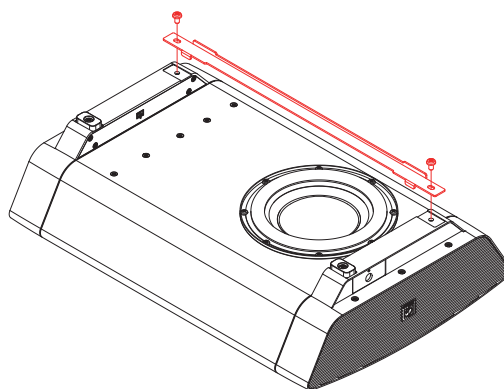

Step 3: Mounting the wall plate

Mount the wall plate to the installation location of the NOBA8. The wall plate has to be fixed using four screws. The exact screw positioning is shown in the drawing below. The used fasteners should be chosen depending on the mounting surface (brick, concrete, wood, gypsum, ...). Make sure the mounting surface can structurally support the weight of the speaker.

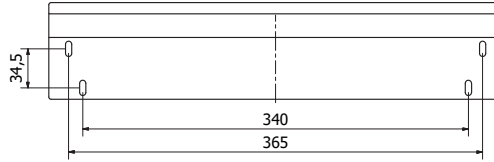

Step 4: Connect the wiring

Once the wall plate is mounted, the wiring shall be connected before hooking the cabinet to the wall plate. For more information how the connections should be made, check chapter 2 and chapter 3 of this instruction manual. When connecting, make sure all wiring is guided and fixed properly so the loose wiring won't touch any moving parts such as the speaker cone.

Step 5: Hook the cabinet to the wall plate:

The last step is hooking the cabinet to the wall plate. This is done by sliding the cabinet support bar over the wall plate followed by a downwards movement of the loudspeaker, as indicated in the drawing below.

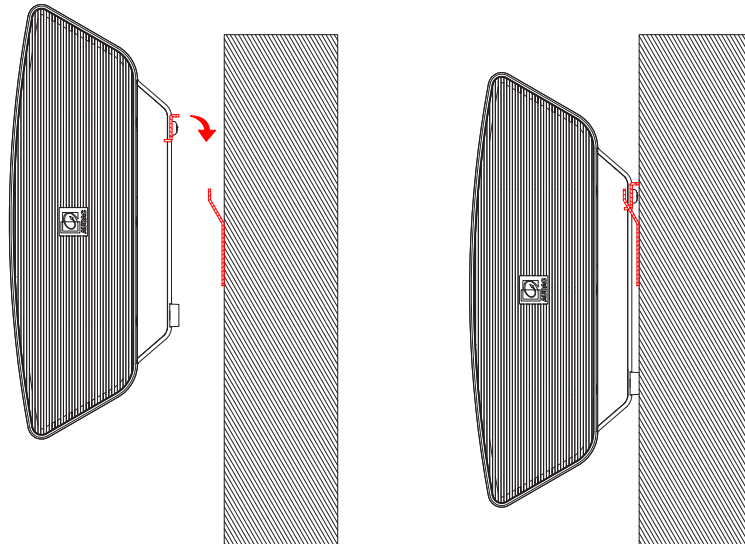

Technical specifications

Max. power		200 Watt
RMS power		100 Watt
Sensitivity subwoofer (1W / 1m)		83 dB
Sound pressure (Max W / 1m)		105 dB
Frequency response ± 3 dB		90 Hz – 350 Hz
Frequency range -10 dB		45 Hz – 350 Hz
Impedance		8 Ω
Driver		8" ferrite with low-loss suspension 2.4" voice coil
Inputs	Type Connectors	Speaker input 2-pin terminal block (5.08 mm pitch)
Construction		4 mm thick aluminium
Dimensions (W x H x D)		558 x 383 x 149 mm
Weight		8.75 Kg
Accessories included		Wall mount bracket
Optional accessories		MBK410C Ceiling mount bracket